

ARJOHUNTLEIGH

GETINGE GROUP

EASYTRACK SYSTEM 2-POST ASSEMBLY

MODEL No: 921XXXX, 922XXXX

Instructions for Use



CE

Design Policy and Copyright

® and ™ are trademarks belonging to the ArjoHuntleigh group of companies.
© ArjoHuntleigh 2013.

As our policy is one of continuous improvement, we reserve the right to modify designs without prior notice. The content of this publication may not be copied either whole or in part without the consent of ArjoHuntleigh.

Table of Contents

Foreword	1
Thank you for choosing ArjoHuntleigh products.	1
Please Read this Manual Thoroughly!	1
Service and Support	1
Manufacturer Information.....	1
Definitions Used in this Manual	1
Safety Instructions	2
Operational Life	2
How to Use this Manual.....	2
Safe Working Load	2
Important Safety Instructions	3
Environmental Advice	3
Homecare Environment Considerations	3
Symbols Used	4
General Symbols	4
Product Description	4
EASYTRACK System Requirements	5
Ceiling Requirements:	5
Floor Requirements:	5
Other Requirements:	5
Room Assessment	6
Assembling the EASYTRACK	7
Requirements	7
Assembling Procedure.....	7
Disassembling the EASYTRACK	10
Requirements:	10
Disassembling Procedure.....	10
Troubleshooting	11
Care and Maintenance	12
Preventive Maintenance Schedule	12
Annual Inspection by an Authorized Technician	12
Cleaning.....	12
Technical Specifications	13
Dimensions	13

Thank you for choosing ArjoHuntleigh products.

Your EASYTRACK® is part of a series of quality products designed specially for home care, nursing homes and other health care uses.

We are dedicated to serving your needs and providing the best products available along with training that will bring your staff maximum benefit from every ArjoHuntleigh product.

Please Read this Manual Thoroughly!

The information in this manual is crucial to the proper use and maintenance of the EASYTRACK. It will help protect your product as well as ensure that it performs to your satisfaction.

Lifting and transferring a person always presents a potential risk. This manual contains safety related information that must be read and understood to help prevent injuries.

WARNING: ArjoHuntleigh strongly advises and warns that to avoid injuries that can be attributed to the use of inadequate parts, only parts designated by ArjoHuntleigh should be used on product and other appliances supplied by ArjoHuntleigh.

WARNING: Unauthorized modifications on any ArjoHuntleigh product may affect its safety. ArjoHuntleigh will not be held responsible for any accidents, incidents or lack of performance that occur as a result of any unauthorized modification to its products.

Do not attempt to service or repair the EASYTRACK. If any item is defective, contact your local ArjoHuntleigh vendor.

Service and Support

A service routine has to be done on your EASYTRACK by ArjoHuntleigh trained service personnel. This will ensure it remains safe and functional.

Please contact your local ArjoHuntleigh vendor for any of the following:

- If you require further information.
- Want to report an unexpected event, change in the performance or a malfunction.
- Need any help in setting up, using or maintaining your EASYTRACK.
- Need replacement parts.

Your ArjoHuntleigh vendor can offer support and service programs to maximize the long-term safety, reliability and value of the product.

Additional copies of this manual can be purchased from your local ArjoHuntleigh agent. When ordering, include the *Instructions for Use* part number (see front page).

Manufacturer Information

This product was manufactured by:

ArjoHuntleigh AB
Hans Michelsensgatan 10
211 20 Malmö
SWEDEN

Definitions Used in this Manual

WARNING:

Means: Failure to understand and follow this instruction may result in injury to yourself and others.

CAUTION:

Means: Failure to follow this instruction may cause damage to the product(s).

NOTE:

Means: Important information regarding correct use of the product.

Safety Instructions

Intended Use

The *EASYTRACK* is a portable track system to be used with ArjoHuntleigh portable lift in a homecare setting, at nursing homes and other assisted living centres. Patient transferring is performed under the supervision of a trained caregiver as per the instructions outlined in this manual in conjunction with the *Instruction for Use* accompanying the ceiling lift.

WARNING: The *EASYTRACK* is for transferring patients only. Do not use the *EASYTRACK* for any other purpose.

Using this *EASYTRACK* outside the scope of its intended use could lead to injuries.

Operational Life

This product is designed and tested for a useful life of seven (7) years or 10000 transfers — whichever comes first—at maximum safe working load (SWL). It is subject to preventive maintenance as specified in the “Care and Maintenance” section.

Time equivalence between the number of transfers versus the number of years is made clear in the following table.

Transfers per Day	Years (10000 transfers)
4	7
6	4.5
8	3.5

WARNING: The manufacturer cannot ensure full safety for a product of which the life span has been exceeded. Wear may cause the breakage of a part and lead to a patient fall.

The life span is the safe operating time period before a complete overhaul is required.

Following are factors that have an impact on the *EASYTRACK* life span:

- aging of the unit;
- transfers per day;
- weight of the patient;
- maintenance frequency.

How to Use this Manual

To ensure the safe operation of the *EASYTRACK*, read the entire manual carefully before operating this product.

If anything is not completely understood, please contact your local ArjoHuntleigh agent for more details. Failure to comply with warnings in this manual may result in injuries.

Keep this manual handy and refer to it as required. Make sure that all operators are regularly trained in the use of the product as per the information found therein.

The *EASYTRACK* must be used as per these safety instructions.

Anyone using the *EASYTRACK* must also have read and understood the instructions in this manual.

Safe Working Load

The *EASYTRACK* has been designed to be used with ArjoHuntleigh ceiling lifts with a safe working load of 200 kg (440 lb) or less.

WARNING: The *EASYTRACK* is intended to be used for residents whose weight is within a specified safe working load (SWL). Do not attempt to lift more than the lowest weight limit indicated on the following:

- the track system
- the “maximum load” label on the ceiling lift
- on the spreader bar
- on the sling.

Overloading any of these elements could lead to a patient fall.

Important Safety Instructions

Before installing or using the *EASYTRACK* always ensure to comply with following safety instructions.

- All labels are read and those that cannot be easily read are replaced.
- The daily maintenance is carried out before using the unit.
- Do not over-tighten ceiling plate as this may cause ceiling to crack.
- Do not drop product; may cause breakage.
- Do not completely submerge in water.
- Do not attempt to over-extend the track past the locking point.
- Do not install product if Neoprene on top or bottom plate appears to be damaged or absent.
- Never hit the posts or lean against them – this might cause unit to become unstable. If this occurs, reassemble the *EASYTRACK* System to ensure the posts are straight.
- Never use the *EASYTRACK* system as a swing.
- Always refrain from swinging patient sideways of track.

Environmental Advice

When disposing of any items associated with the product, contact local authorities for information.





Homecare Environment Considerations



WARNING: The *EASYTRACK* is not intended to be operated by children. Serious injuries could occur.

NOTE: Rigorous cleaning actions should be done when the *EASYTRACK* is exposed to an animal. Pet hair trapped inside the device can reduce the product performance.

Symbols Used

General Symbols

	Manufacturer's name and address. May also point out manufacturing date.
	Product complies with the medical device directive 93/42/EEC.
	Points out the manufacturer's catalogue number.
	Indicates a potential risk, see <i>Instructions for Use</i> for corrective action.
	Points out the manufacturer's serial number.

SWL	SWL is the maximum load the device is rated for safe usage.
	Refer to the <i>Instructions for Use</i> (IFU).
	Incorrect
	Correct

Product Description

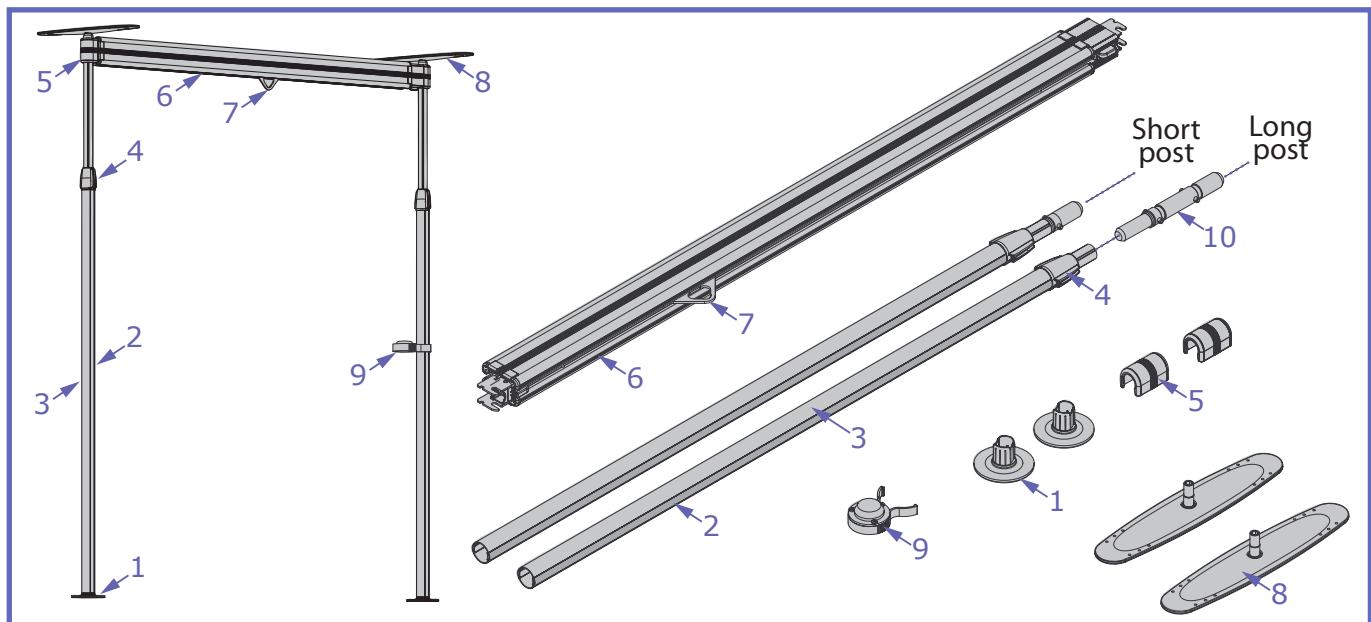

Fig. 1

Legend

- | | |
|-------------------|--|
| 1) Foot Plate | 6) Extendable Track |
| 2) Plastic Strip | 7) Trolley |
| 3) Standard Post | 8) Ceiling Plate |
| 4) Locking Handle | 9) Clip-on Level |
| 5) Track End Cap | 10) Post extension (Supplied only with Kit featuring long posts) |

EASYTRACK System Requirements

CAUTION:

- If you are unsure of the strength or stability of your floor and / or ceiling – do not install the *EASYTRACK* System – consult your local ArjoHuntleigh agent.
- The *EASYTRACK* must not be used with any type of suspended ceiling such as: suspended drywall, acoustic tiles, etc.
- Do not install on a ceiling with water damage.

Ceiling Requirements:

The *EASYTRACK* must be installed to a rigid ceiling which have a framework above it.

- Ceiling structure must have a maximum of 610 mm (24") between the trusses or joists.
- Ceiling must be made of wood or 12.7 mm (1/2") sheet rock or thicker.

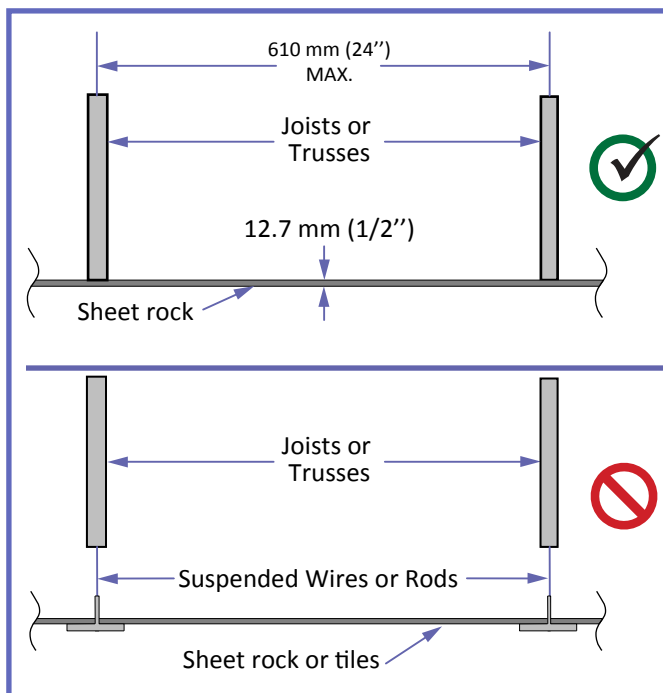

Fig. 2

- Ceiling must be clear of any dust, grease, water or any foreign substance.

CAUTION: Installation on a plaster ceiling may cause cracking, ArjoHuntleigh cannot be held responsible for damage.

WARNING: A build-up of nicotine, grease or water on the ceiling affects the integrity of the *EASYTRACK* system which could lead in patient fall.

Floor Requirements:

- Flooring must comply to local building code standards.

WARNING: Termites or water damages may affect the structure of the floor.

- Floor must be clear of any dust, grease, water or any foreign substance.
- Floor must have a slope of less than 0.5°. See drawing below to determine the floor slope. Use a level or contact a contractor if unsure of floor slope.

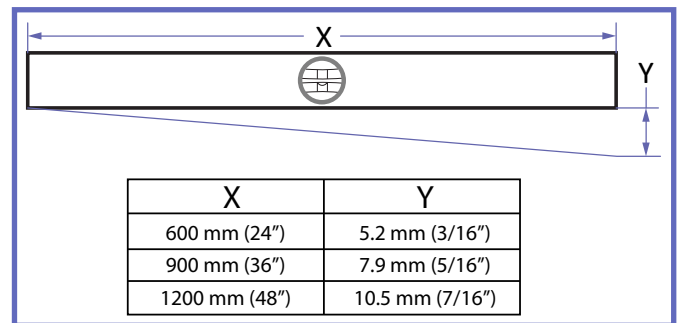

Fig. 3

Other Requirements:

WARNING: Use the clip-on level included with kit to ensure all posts are straight – failure to do so may lead to injury.

- A maintenance check should be done on a monthly basis to ensure all posts are levelled, see "Care and Maintenance" section.

Room Assessment

Before installing the *EASYTRACK* prepare the installation as follows:

- 1) Survey the room where you plan to install the *EASYTRACK* system.
 - Make sure the room meets all the specifications outlined in “*EASYTRACK System Requirements*” section.
- 2) Make sure the pick-up point will be inside the transfer zone:
 - Over a bed : approximately 915 - 1020 mm (36 - 40”) from the head of the bed.
 - Over a tub: approximately 400 - 460 mm (16 - 18”) from the end of the tub.
 - Allow 1000 mm (39”) of the open area for transfer working space.

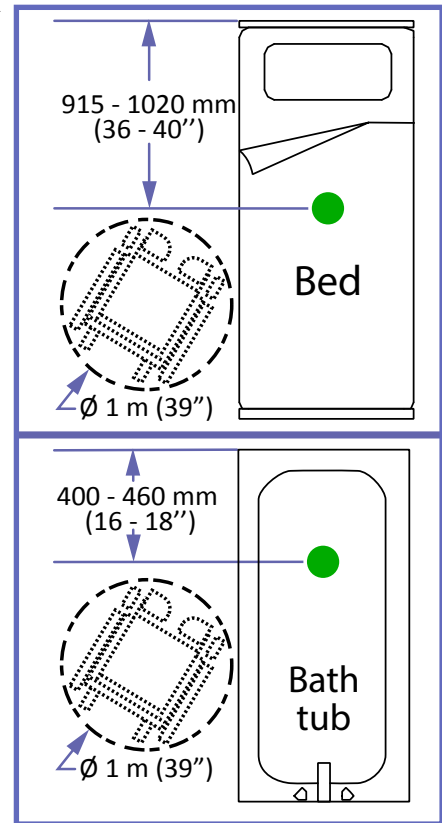

Fig. 4

- 3) Transfers should only take place between the *EASYTRACK* System’s posts, see Fig. 5.

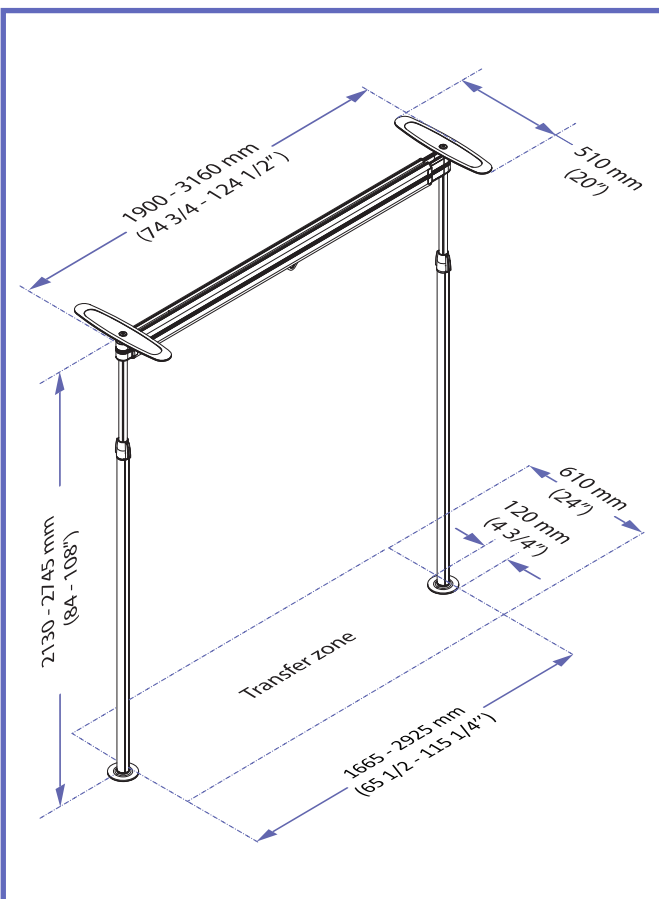

Fig. 5

NOTE: Although it is not a requirement to place the posts directly under a joist in the ceiling, it is preferable. It does not matter which direction the plates are facing.

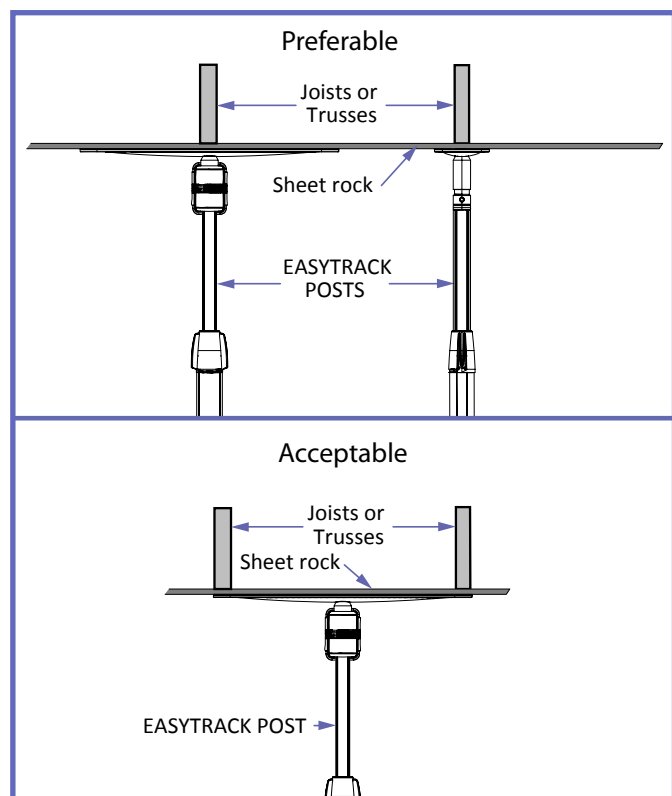

Fig. 6

Assembling the *EASYTRACK*

Requirements

- Step ladder
- Tape measure
- Someone to assist you

Assembling Procedure

WARNING: Proceed with the inspection of the *EASYTRACK* system before installing. Refer to "Care and Maintenance" on page 12. Failure to do so may lead to injury.

- 1) Remove the round blue cap from the top of each post by pulling them away from the post.

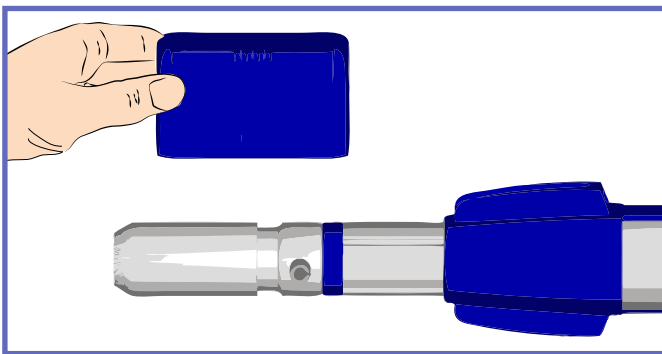

Fig. 7

- 2) Remove the blue plastic strips from each side of the posts. Take one end and pull gently.

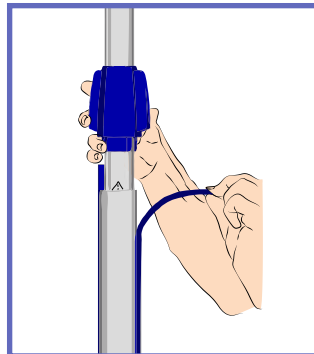

Fig. 8

- 3) Place one round foot plate (see Fig. 1 - item № 1) on the floor where you want to place the first post of the *EASYTRACK* System.

- 4) Take one of the posts out of the box. Turn the post upright. Place the clip-on level (see Fig. 1 - item № 9) onto the post at approximately waist height.

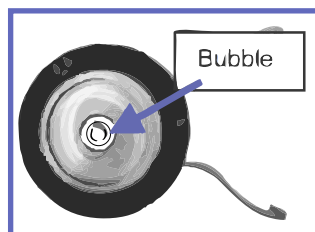

Fig. 9

- 5) For kit featuring long posts, take the post extension (see Fig. 1 - item № 10) out of the box and insert it into the post until it snaps into place.

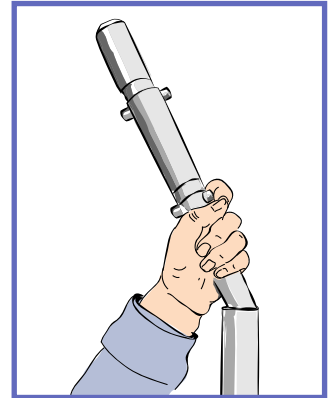

Fig. 10

- 6) Place the post onto the foot plate and press down to tighten. Pay attention to the shape of the post and foot plate before pressing the post down onto the foot plate.

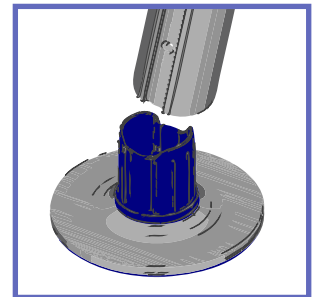

Fig. 11

- 7) Place the top plate into the top of the post, press firmly and evenly downward until the top plate "clicks" into place.

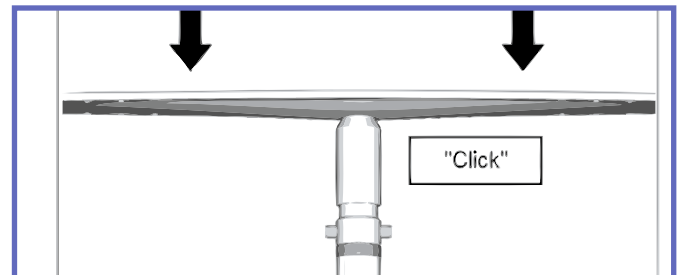

Fig. 12

- 8) Extend the post quickly towards the ceiling by pulling the top portion and holding the bottom portion. The post should be within 76 mm (3") to touching the ceiling.

If the top of the post is more than 76 mm (3") from the ceiling:

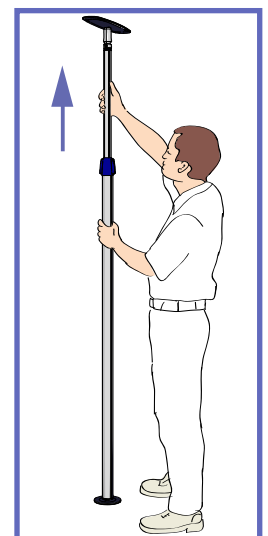

Fig. 13

- a) Extend post slightly to remove pressure.

- b) Press in metal pins on both sides of the post. Metal pins cannot be pressed in when there is downward pressure on them. Pressure must be released to press in pin.

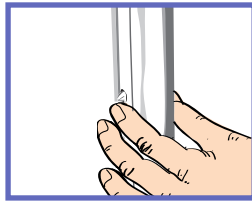

Fig. 14

WARNING: Red mark must not be visible for the post to be safely secured (see the warning label, apposed on each post, as shown in Fig. 19).

Never use the *EASYTRACK* system when a red mark is visible as it could fall down resulting in injuries.

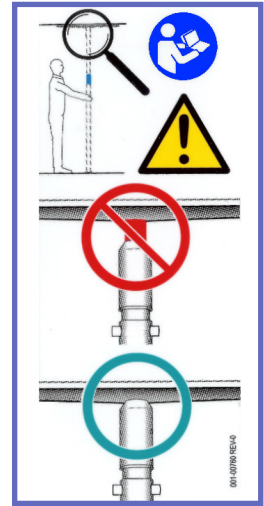

Fig. 19

- c) Extend the post until the top plate is less than 76 mm / 3" from the ceiling.
- 9) Lift the blue locking handle out of the lower portion of the post (see Fig. 1 - item № 4). Using the blue piece as a handle, twist the post as shown in Fig. 15:

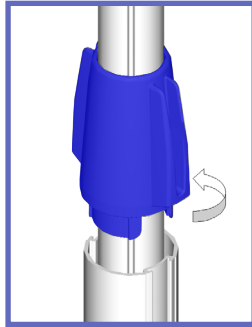

Fig. 15

- a) Top portion – turn counter-clockwise.
b) Bottom portion – hold firmly.

- 10) Before the *EASYTRACK* post tightens against the ceiling; check the clip-on level to make sure the bubble is in the centre of the circle. Tilt the post until the bubble reaches the centre of the circle, see Fig. 16 and Fig. 17.

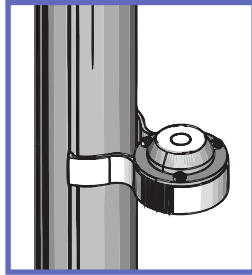

Fig. 16

NOTE: Do not over-tighten the post. Tighten only until red mark disappears. Over-tightening post may cause damage to the ceiling.

- 12) Remove the level from the post by sliding it up off the bottom portion of the post. Slide the blue locking device down to fit into the bottom part of the post to lock the post in place.

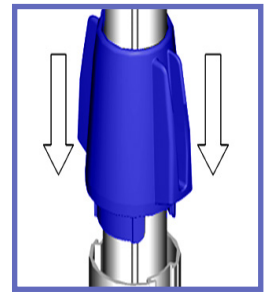

Fig. 20

NOTE: Make sure clip-on level is fully attached to the post. Failure to attach level properly could give an incorrect reading. Level should "Click" into place.

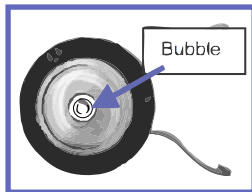

Fig. 17

NOTE: Once the blue locking handle is pressed into the lower portion of the post, the post can be turned as a whole, except for the top plate and foot plate. This will not lower the post. The post must turn to enable you to attach the track.

- 11) Once the bubble is in the centre of the clip-on level – continue to tighten **only until the red mark at the top of the post is no longer visible**.

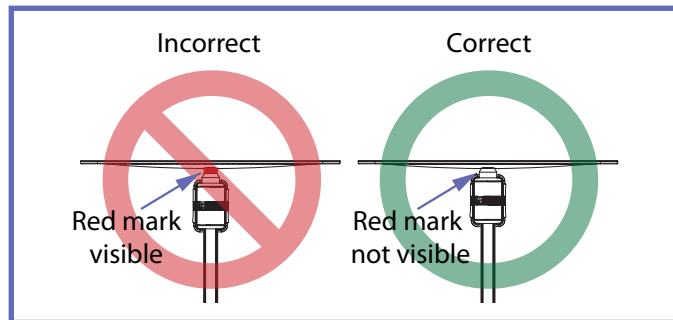

Fig. 18

- 13) Repeat procedure from steps (3) for the second post.

NOTE: Make sure that all posts are far enough from each other to allow the track to latch on (minimum distance between each post: 1.90 meters (75").

- 14) After both posts have been secured, install the end of the track (Fig. 1 – item № 6) marked "Step 1" onto one post.

If the pins on top of the post are not facing the desired direction, place the track onto pins and rotate post to desired direction.

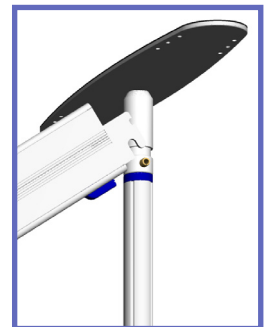

Fig. 21

NOTE: Tilt the track upward (45°) to latch the track onto the post.

NOTE: For kit featuring long posts, you can insert the track onto either set of pins (top or bottom) depending on your needs.

15) Raise the track slightly, and then extend the track to the second post.

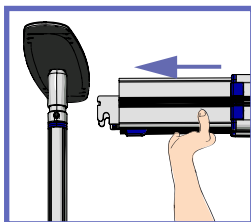

Fig. 22

NOTE: Do not squeeze sides of track together when attempting to extend or shorten the track. Squeezing the track makes it more difficult to slide.

16) Latch the end of the track marked “Step 2” onto the second post. The track should “click” in place. Press up on the track to make sure it is locked into place.

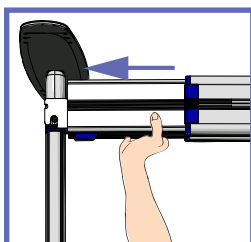

Fig. 23

WARNING: For kit featuring long posts, the track **MUST** be installed on the set of pins at the same height on both ends as shown in Fig. 24. Not following this advice could make the system unstable and lead to injuries.

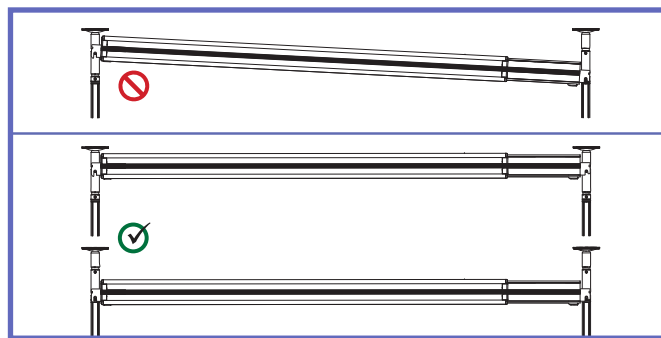

Fig. 24

17) Install one blue end cap on each end of the track.

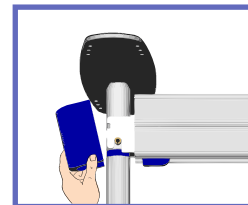

Fig. 25

18) Put the level in a safe place, as you may need it in the future.

19) Place the blue plastic strips on both sides of the posts by pinching the strip in order to insert it into the grooves. Start at the bottom of the post.

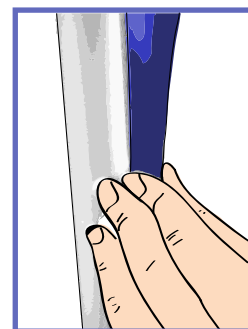

Fig. 26

Final Inspection Prior Usage

Before using the *EASYTRACK*, review the installation to make sure it is safe for usage.

WARNING: Use the clip-on level included with the kit to ensure all posts are straight – failure to do so may lead to injury.

- Check your installation against Fig. 27.
- Make sure the red mark on top of each posts is not visible.
- Make sure that the extendable track is locked into place and that it is levelled.
- Make sure that the blue locking handle is secured down into the lower portion of each posts.

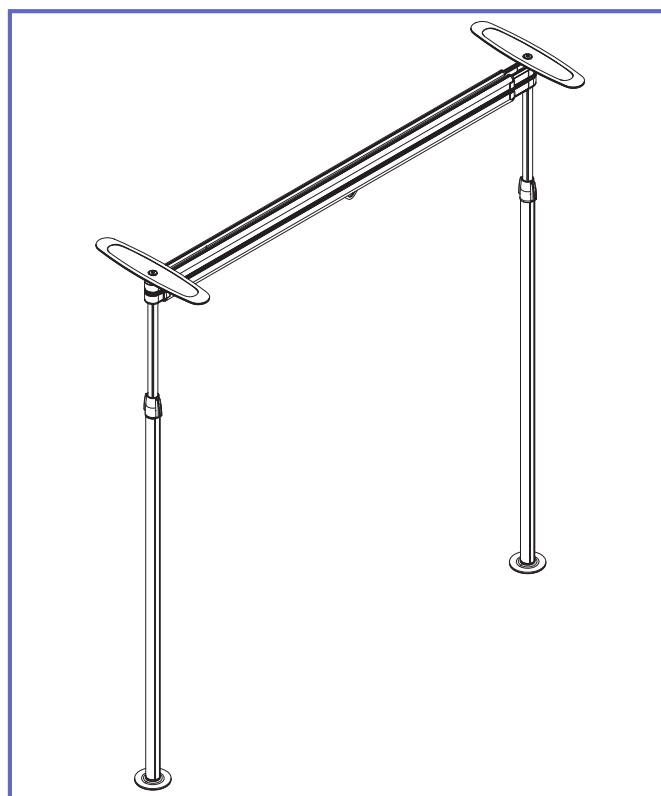

Fig. 27

Disassembling the *EASYTRACK*

Requirements:

- Step ladder
- Someone to assist you

Disassembling Procedure

1) Remove the lift from the assembly before adjusting or disassembling the *EASYTRACK* System.

2) Remove plastic strips from the sides of the posts. To remove, take one end of the strip and gently pull outward.

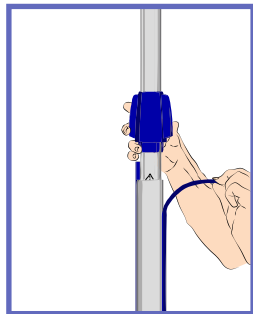

Fig. 28

3) Remove the round blue cap from the ends of the track, by pulling them away from the post.

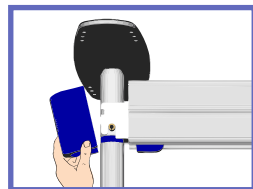

Fig. 29

4) Using a step ladder, reach under the section of the track labelled "Step 2". Slightly pull the blue tab away from the post to release the lock on the track.

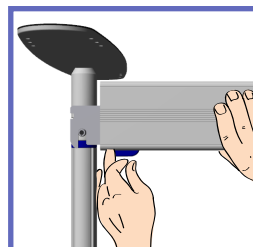

Fig. 30

5) Push end of track to shorten the track and tilt the track downward (45°). The other end of the track should easily be released from the post.

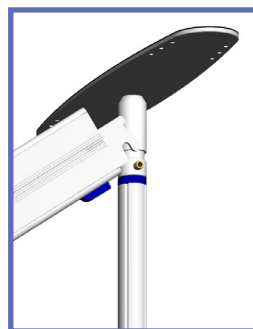

Fig. 31

Do not squeeze sides of track together when attempting to extend or contract the track. Squeezing the track makes it more difficult to slide.

6) To remove the post, slide up the blue locking device out of the bottom part of the post to unlock it.

7) Loosen the post by rotating the handle as shown in Fig. 32:

- a) Top part of post – turn clockwise.
- b) Bottom part of post – hold firmly.

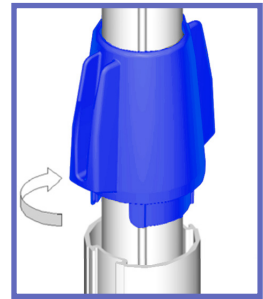

Fig. 32

8) Once the post is loose enough to allow you to move the post, slide the top portion of the post down :

- a) Press the blue locking device back into the bottom part of the post.
- b) Slightly raise the top portion of the post.
- c) Press in metal pin on both sides of the post.

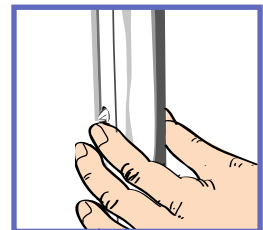

Fig. 33

NOTE: Metal pins cannot be pressed in when there is downward pressure on them. Pressure must be released to press in pin.

- d) Push top portion of post downward.
- e) Repeat until the metal pins are no longer visible and the top of the post is only 152-200 mm (6-8") above the blue locking handle.

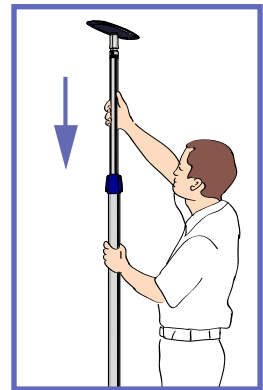

Fig. 34

9) Remove the top plate from the post by pressing up evenly.

10) Remove the post from the foot plate by stepping on both sides with your feet and pulling the post up.

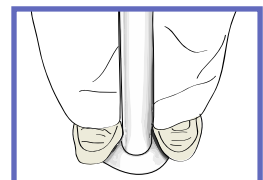

Fig. 35

11) Place all pieces into a box or a bag to protect them from dust and / or damage.

12) Repeat from steps (7) for the second post.

13) Put the level with the rest of the *EASYTRACK* System for the next time you need to assemble it.

PROBLEM	TO CHECK
1) Trolley moves substantially on its own when the <i>Easytrack</i> System is fully assembled.	<ul style="list-style-type: none"> • Are posts, straight? Review assembling instructions, steps (10) and (11). • Is the track secured to the posts? Press up on the track to make sure it is latched onto the post. • Is the ceiling level? Make sure ceiling complies with ceiling requirements.
2) Extendable track comes completely apart during assembly.	<ul style="list-style-type: none"> • Track was pulled past the locking device. <ol style="list-style-type: none"> 1) Check locking device inside track (top of track above the trolley) to make sure it is not damaged. Replace trolley if damaged. 2) Put track back together at a slight angle and slide together. 3) Slowly extend track out again to make sure locking device clicks into place. 4) Slowly compress the track again.
3) Not able to push pin to assemble / disassemble post.	<ul style="list-style-type: none"> • Is the post still tight against the ceiling? Release pressure on posts by unscrewing blue locking device. See disassembling instruction, step (7). • Are you lifting the upper portion of the post slightly to release pressure? Raise upper portion of post first, and then push the pin in. See assembling instruction, step (8) / disassembling instruction, step (9). • Is the blue locking handle up out of the lower portion of the post when turning the upper portion clockwise? See assembling instruction, step (9).
4) Not able to tighten post enough to hide the red mark.	<ul style="list-style-type: none"> • Have you extended the post long enough? <ol style="list-style-type: none"> a) Release pressure using the blue locking handle. See disassembling instruction, step (7). b) Slide post up one or more notches, then screw the upper portion of the post to tighten. See assembling instruction, steps (8) and (9). c) If the post has been “unscrewed” to the maximum and will not turn anymore – reverse direction to shorten the post several millimetres (inches), then slide the post up another notch. See assembling instruction, steps (8) and (9). • Is the blue locking handle up out of the lower portion of the post when turning the upper portion clockwise? See assembling instruction, step (9). • Are you holding the top portion of the post firm while twisting the upper portion clockwise? See assembling instruction, step (9).
5) Posts do not appear stable.	<ul style="list-style-type: none"> • Make sure red marks are not visible? <ul style="list-style-type: none"> • See assembling instruction, step (11). • See troubleshooting problem #4. • Is Neoprene (rubber) on either top plate or foot plate damaged or dirty? <ul style="list-style-type: none"> • Clean both foot plate and ceiling plate with soap and warm water. Make sure they are completely dry before re-assembling post. • Is ceiling clean? <ul style="list-style-type: none"> • Clean ceiling and/or floor.
6) Trolley does not roll in track smoothly.	<ul style="list-style-type: none"> • Is track clean? Clean track with damp cloth. • Is trolley centred in track? Re-centre trolley. • Is the trolley damaged? Replace trolley.

Care and Maintenance

Preventive Maintenance Schedule

The *EASYTRACK* is subject to wear and tear, and the following actions must be performed when specified to ensure that the product remains within its original manufacturing specification.

WARNING: The points on this checklist are the minimum the manufacturer recommends. In some cases more frequent inspections should be carried out. Continuing to use the *EASYTRACK* without conducting regular inspections will seriously compromise the user and resident/patient's safety. Preventive maintenance specified in this manual can prevent accidents.

WARNING: Safety related maintenance and authorized service must be carried out by qualified personnel, fully trained in servicing procedures by ArjoHuntleigh and equipped with correct tools and proper documentation, including Parts List and Service Manual. Failure to meet these requirements could result in personal injuries and/or unsafe equipment.

POINTS TO BE INSPECTED BY USER/SERVICE TECHNICIAN	FREQUENCY				
	Annually / every 1400 transfer / every 50 assembling*				
	Monthly				
	Before every use				
	Before installing	↓	↓	↓	↓
Carefully inspect all the components. If any pieces are missing or appear damaged – do not assemble. Contact your local ArjoHuntleigh agent for further instructions.	•	•	•	•	•
Ensure all components are in working order.	•	•	•	•	•
Ensure that the extendable track cannot be extended beyond the red marks.	•	•	•	•	•
Ensure that the holes on both sides of every posts are not flared due to wearing and that the pins are in good working order.	•	•	•	•	•
Using the clip-on level, make sure that all posts are straight. If any post is not straight remove the extendable track and level post accordingly.		•	•	•	•
Red mark on top of each post (under the top plate) is not visible.		•	•	•	•
The extendable track is secured in place. Press up on the track to make sure that it is locked onto the post.		•	•	•	•
Clean inside of the extendable track to ensure there is no dust or grease build-up inside of track			•	•	•
Check to make sure that the trolley moves freely along the track			•	•	•
Make sure the padding on the foot and top plate is clear of any foreign substance and is not damaged. Have the paddings replaced accordingly.	•				•
WARNING: If any of the above inspection point fails, DO NOT USE the <i>EASYTRACK</i> system until appropriate corrective action is taken.					

* Which ever comes first: Annually - every 1400 patient transfer cycles - every 50 assembling/disassembling cycles.

Annual Inspection by an Authorized Technician

The *EASYTRACK* must be inspected by a qualified ArjoHuntleigh technician on an annual basis to ensure the proper functioning of its components, as well as the safety of the patients and care givers that use the *EASYTRACK*. Please contact your local representative to make arrangements.

NOTE: If the product does not work as intended, immediately contact your local ArjoHuntleigh agent for support.

Cleaning

To clean the *EASYTRACK*, wipe it down with a damp cloth using warm water and mild detergent.

CAUTION: Do not use phenol, chlorine or any other type of solvent that may damage the finish.

To ensure a better rolling surface for the trolley wheels, clean the inside of the track every four months. To do so, insert a damp cloth in the opening and slide it from one end of the track to the other.

Technical Specifications

PRODUCT INFORMATION		<i>EASYTRACK</i> 2-post system № 9220010
Weight	Total: 19.73 kg (43.4 lb) Post Assembly: 3.9 kg (8.58 lb) each Track Assembly: 11.9 kg (26.2 lb)	
Max. safe working load	200 kg (440 lb)	
Range	Extendable Track: 1900 - 3160 mm (74 - 124 1/2") Post: 2130 - 2745 mm (84 - 108")	
Material	Aluminium	
RECYCLING		
Package	Cardboard recyclable	
The <i>EASYTRACK</i>	Separated and recycled	

Dimensions

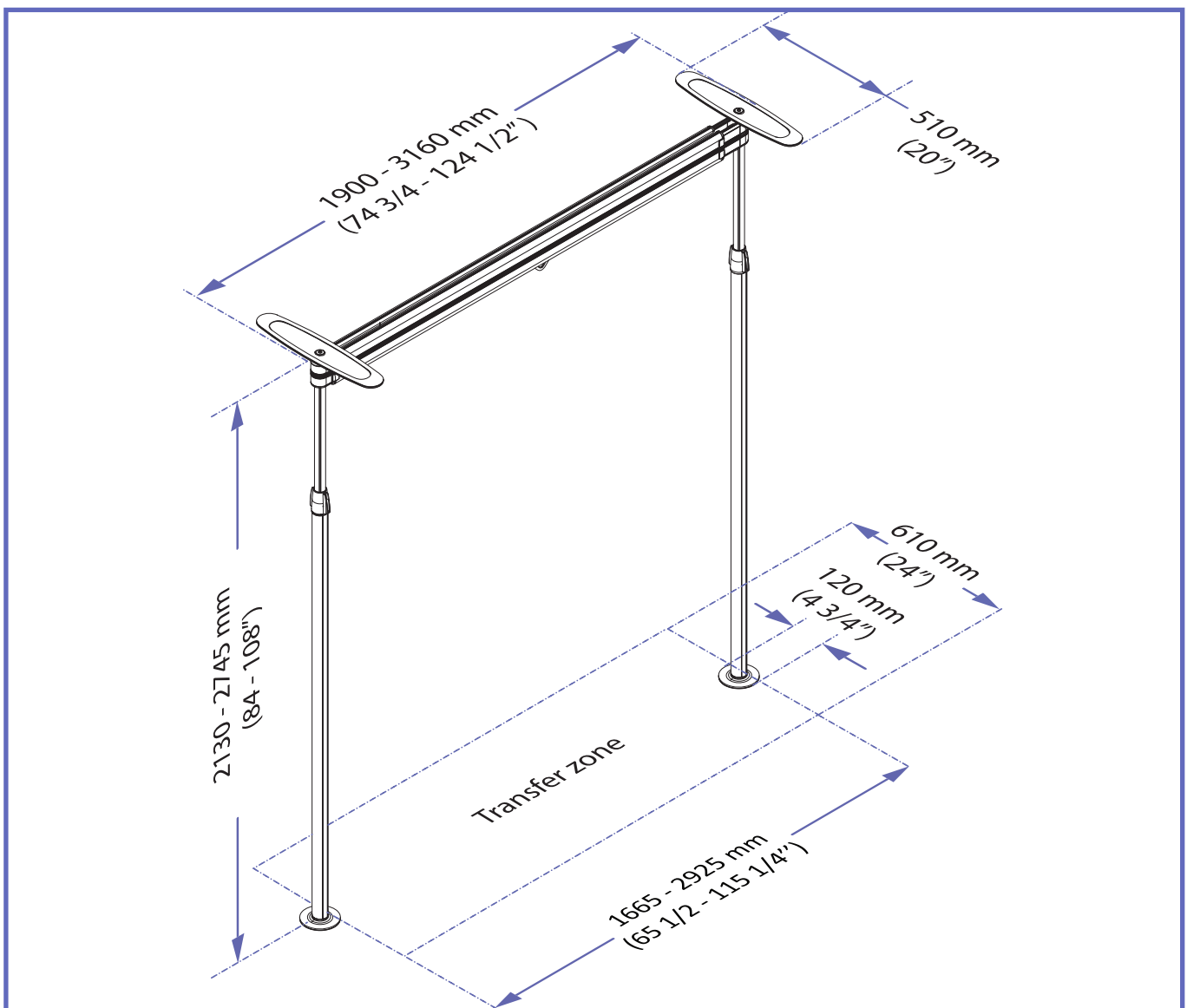

Fig. 36

001.10600.EN rev. 12

AUSTRALIA

ArjoHuntleigh Pty Ltd
78, Forsyth Street
O'Connor
AU-6163 Western Australia
Tel: +61 89337 4111
Free: +1 800 072 040
Fax: + 61 89337 9077

BELGIQUE / BELGIË

ArjoHuntleigh NV/SA
Evenbroekveld 16
BE-9420 ERPE-MERE
Tél/Tel: +32 (0) 53 60 73 80
Fax: +32 (0) 53 60 73 81
E-mail: info@arjohuntleigh.be

BRASIL

Maquet do Brasil
Equipamentos Médicos Ltda
Rua Tenente Alberto Spicciati, 200
Barra Funda, 01140-130
SÃO PAULO, SP - BRASIL
Fone: +55 (11) 2608-7400
Fax: +55 (11) 2608-7410

CANADA

ArjoHuntleigh
90 Matheson Boulevard West
Suite 300
CA-MISSISSAUGA, ON, L5R 3R3
Tel/Tél: +1 905 238 7880
Free: +1 800 665 4831 Institutional
Free: +1 800 868 0441 Home Care
Fax: +1 905 238 7881
E-mail: info.canada@arjohuntleigh.com

ČESKÁ REPUBLIKA

ArjoHuntleigh s.r.o.
Hlinky 118
CZ-603 00 BRNO
Tel: +420 549 254 252
Fax: +420 541 213 550

DANMARK

ArjoHuntleigh A/S
Vassingerødvej 52
DK-3540 LYNGE
Tel: +45 49 13 84 86
Fax: +45 49 13 84 87
E-mail:
dk_kundeservice@arjohuntleigh.com

DEUTSCHLAND

ArjoHuntleigh GmbH
Peter-Sander-Strasse 10
DE-55252 MAINZ-KASTEL
Tel: +49 (0) 6134 186 0
Fax: +49 (0) 6134 186 160
E-mail: info-de@arjohuntleigh.com

ESPAÑA

ArjoHuntleigh Ibérica S.L.
Ctra. de Rubí, 88 1ª planta - A1
08173 Sant Cugat del Vallés
ES- BARCELONA 08173
Tel: +34 93 583 11 20
Fax: +34 93 583 11 22
E-mail: info.es@arjohuntleigh.com

FRANCE

ArjoHuntleigh SAS
2 Avenue Alcide de Gasperi
CS 70133
FR-59436 RONCQ CEDEX
Tél: +33 (0) 3 20 28 13 13
Fax: +33 (0) 3 20 28 13 14
E-mail: info.france@arjohuntleigh.com

HONG KONG

ArjoHuntleigh (Hong Kong) Ltd
1510-17, 15/F, Tower 2
Kowloon Commerce Centre
51 Kwai Cheong Road
Kwai Chung
HONG KONG
Tel: +852 2207 6363
Fax: +852 2207 6368

INTERNATIONAL

ArjoHuntleigh International Ltd
ArjoHuntleigh House
Houghton Hall Park
Houghton Regis
UK-DUNSTABLE LU5 5XF
Tel: +44 (0) 1582 745 800
Fax: +44 (0) 1582 745 866
E-mail:
international@arjohuntleigh.com

ITALIA

ArjoHuntleigh S.p.A.
Via di Tor Vergata 432
IT-00133 ROMA
Tel: +39 (0) 6 87426211
Fax: +39 (0) 6 87426222
E-mail: Italy.promo@arjohuntleigh.com

NEDERLAND

ArjoHuntleigh Nederland BV
Biezenwei 21
4004 MB TIEL
Postbus 6116
4000 HC TIEL
Tel: +31 (0) 344 64 08 00
Fax: +31 (0) 344 64 08 85
E-mail: info.nl@arjohuntleigh.com

NEW ZEALAND

ArjoHuntleigh Ltd
41 Vestey Drive
Mount Wellington
NZ-AUCKLAND 1060
Tel: +64 (0) 9 573 5344
Free Call: 0800 000 151
Fax: +64 (0) 9 573 5384
E-mail: nz.info@ArjoHuntleigh.com

NORGE

ArjoHuntleigh Norway AS
Olaf Helsets vei 5
N-0694 OSLO
Tel: +47 22 08 00 50
Faks: +47 22 08 00 51
E-mail:
no.kundeservice@arjohuntleigh.com

ÖSTERREICH

ArjoHuntleigh GmbH
Dörrstrasse 85
AT-6020 INNSBRUCK
Tel: +43 (0) 512 204 160 0
Fax: +43 (0) 512 204 160 75

POLSKA

ArjoHuntleigh Polska Sp. z o.o.
ul. Ks Piotra Wawrzyniaka 2
PL-62-052 KOMORNIKI (Poznan)
Tel: +48 61 662 15 50
Fax: +48 61 662 15 90
E-mail: arjo@arjohuntleigh.com

PORTUGAL

ArjoHuntleigh em Portugal
MAQUET Portugal, Lda. (Distribuidor Exclusivo)
Rua Poeta Bocage n.º 2 - 2G
PT-1600-233 Lisboa
Tel: +351 214 189 815
Fax: +351 214 177 413
E-mail: Portugal@arjohuntleigh.com

SUISSE / SCHWEIZ

ArjoHuntleigh AG
Fabrikstrasse 8
Postfach
CH-4614 HÄGENDORF
Tél/Tel: +41 (0) 61 337 97 77
Fax: +41 (0) 61 311 97 42

SUOMI

Oy Vestek AB
Martinkuja 4
FI-02270 ESPOO
Puh: +358 9 8870 120
E-mail: info@vestek.fi

SVERIGE

ARJO Scandinavia AB
Hans Michelsensgatan 10
SE-211 20 MALMÖ
Tel: +46 (0) 10 494 7760
Fax: +46 (0) 10 494 7761
E-mail: kundservice@arjohuntleigh.com

UNITED KINGDOM

ArjoHuntleigh UK
ArjoHuntleigh House
Houghton Hall Park
Houghton Regis
UK-DUNSTABLE LU5 5XF
Tel: +44 (0) 1582 745 700
Fax: +44 (0) 1582 745 745
E-mail: sales.admin@arjohuntleigh.com

USA

ArjoHuntleigh Inc.
2349 W Lake Street Suite 250
US-Addison, IL 60101
Tel: +1 630 307 2756
Free: +1 800 323 1245 Institutional
Free: +1 800 868 0441 Home Care
Fax: +1 630 307 6195
E-mail: us.info@arjohuntleigh.com

ARJOHUNTLEIGH

GETINGE GROUP

GETINGE GROUP is a leading global provider of products and systems that contribute to quality enhancement and cost efficiency within healthcare and life sciences. We operate under the three brands of **ArjoHuntleigh**, **GETINGE** and **MAQUET**. **ArjoHuntleigh** focuses on patient mobility and wound management solutions. **GETINGE** provides solutions for infection control within healthcare and contamination prevention within life sciences. **MAQUET** specializes in solutions, therapies and products for surgical interventions and intensive care.

www.ArjoHuntleigh.com



ArjoHuntleigh AB
Hans Michelsensgatan 10
211 20 Malmö
SWEDEN

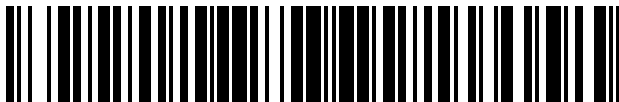

001.10600.EN